



Look ahead to **increased productivity** and **lasting quality** in a machine built specifically to meet your requirements. Invest in a new high performance **Predator Series** from **Cutting Systems, Inc.** Committed to providing the **best cutting machines and after sales support in the industry.**

HEAVY-DUTY MULTI-PROCESS CUTTING SYSTEM



Shown with optional water table

VITAL STATISTICS

- Plasma / Flame Cutting Machine
- 10' Effective Cutting Width
- Pedestal or Floor Mounted Rail System
- Heat Shield for Heavy Plate Cutting
- Burny Phantom PC Based Control
- AC or DC Precision Drive Systems
- Planetary Motor / Gearbox Assemblies
- Precision Rack & Pinion Dual Side Drive
- Precision Rectangle Ways
- High Volume Gas Control System
- Up to (8) CSI Motorized Oxy/Fuel Lifter Stations
- 130 - 260 amp Conventional or High Definition Plasma System (Max 2)
- Automatic Plasma Torch Height Control & Collision Sensor
- Tongue & Groove "T" Rail
- Water or Down Draft Table Available
- Maximum Material Thickness 14"



CUTTING SYSTEMS, INC.

P 216/928-0500

F 216/928-0502

www.cuttingsystems.com

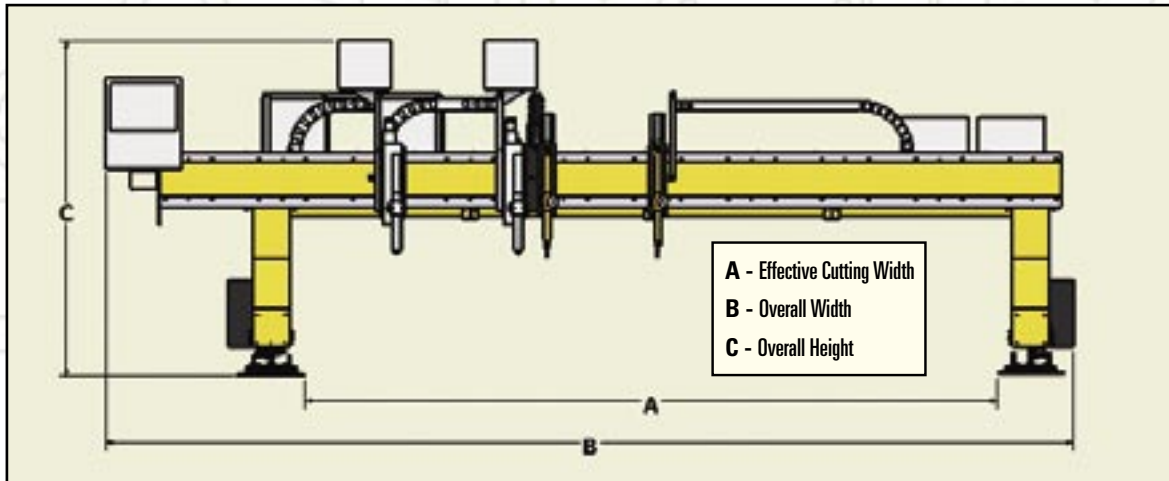

DIMENSIONS

Max Stations	A	B	C
8	120"	17'	6'

OPTIONS

- Burny 10 LCD Plus PC Based CNC Control
- Plasma Marker or Pneumatic Punch Marking Station
- AutoDrill for Precision Drilling up to 1-1/4"
- CSI Operator Console
- Automatic Torch Ignitors
- RS-232 Communications Package
- Networking Kit with Fiber Optic Cable
- TurboNest BE Trueshape Nesting & Remnant Digitizing Loaded on Control
- Multiple Cad & Desktop Software Solutions
- Laser Mapping Machine Motion
- Up to 140' Effective Cutting Length
- Overhead Power Track



CUTTING SYSTEMS, INC.

Cleveland, Ohio 44105

P: 216.928.0500 • F: 216.928.0502

www.cuttingsystems.com