

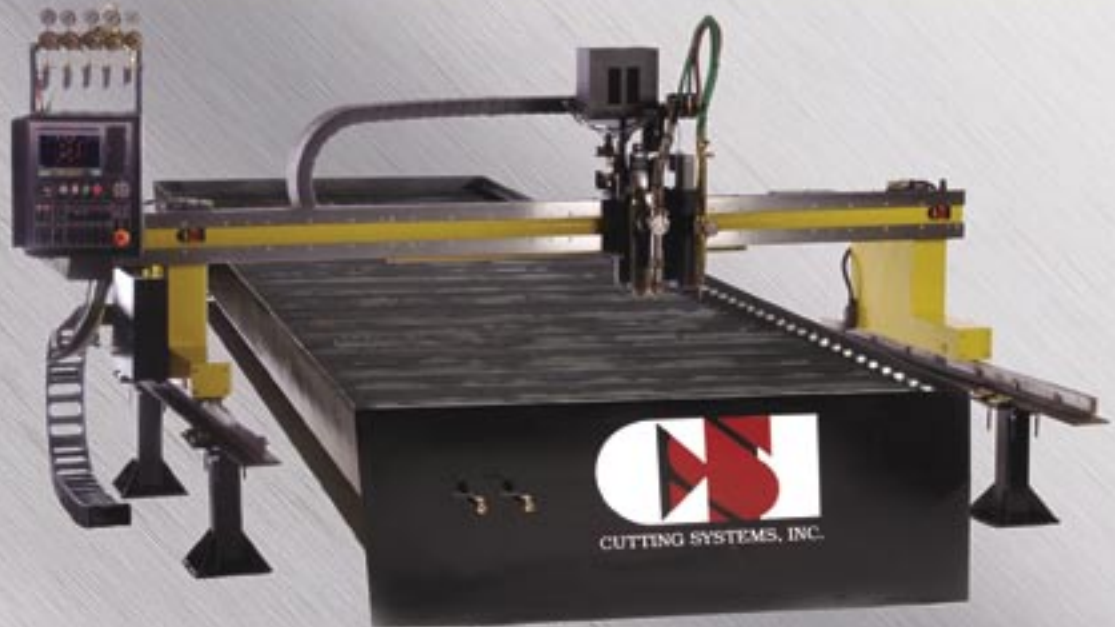

Look ahead to **increased productivity** and **lasting quality** in a machine built specifically to meet your requirements. Invest in a new high performance **Predator Series** from **Cutting Systems, Inc.** Committed to providing the **best cutting machines and after sales support in the industry.**

## COMBINATION PLASMA & OXY/FUEL CUTTING SYSTEM



Shown with optional water table

### VITAL STATISTICS

- Plasma / Flame Cutting Machine
- 4', 6', 8', Effective Cutting Width
- Burny Phantom PC Based Control
- AC or DC Precision Drive Systems
- Planetary Motor / Gearbox Assemblies
- Precision Rack & Pinion Dual Side Drive
- Precision Rectangle Ways
- Hi Volume Gas Control System
- Up to (4) CSI Motorized Oxy/Fuel Lifter Stations
- 130 – 260 amp Conventional or High Definition Plasma Systems (Max 2)
- Automatic Plasma Torch Height Control & Collision Sensor
- Tongue & Groove "T" Rail
- Water or Down Draft Table Available
- Maximum Material Thickness 6"



CUTTING SYSTEMS, INC.

**P** 216/928-0500

**F** 216/928-0502

[www.cuttingsystems.com](http://www.cuttingsystems.com)

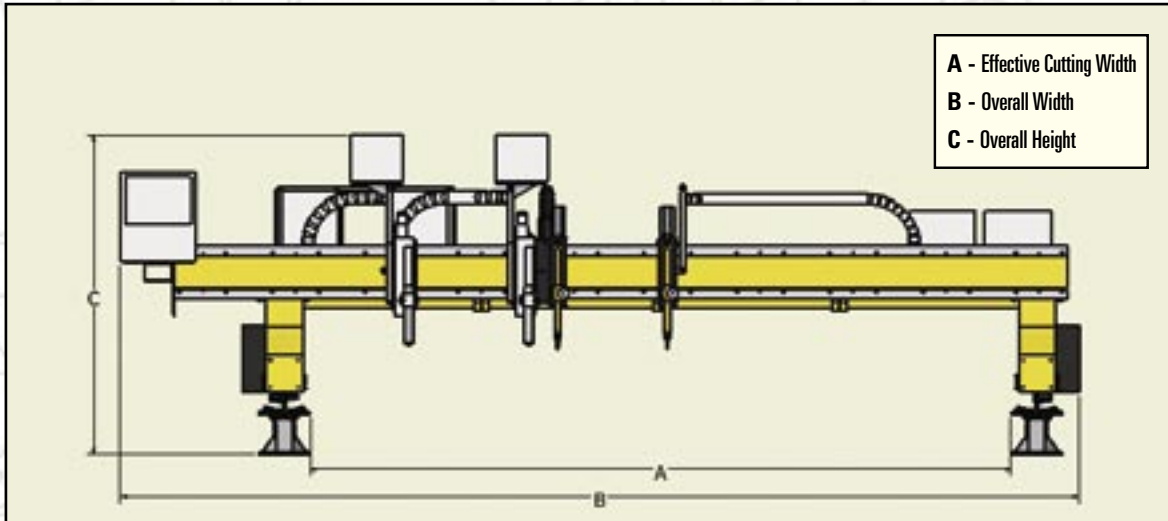

### DIMENSIONS

Max Stations	A	B	C
3	48"	9'	5'
3	72"	11'	5'
4	96"	14'	5'

### OPTIONS

- Burny 10 LCD Plus PC Based CNC Control
- RS-232 Communications Package
- Plasma Marker or Pneumatic Punch Marking Station
- Networking Kit with Fiber Optic Cable Extraction
- AutoDrill for Precision Drilling or Tapping up to 9/16"
- TurboNest BE Trueshape Nesting & Remnant Digitizing Loaded on Control
- CSI Operator Console
- Multiple Cad & Desktop Software Solutions
- Automatic Torch Igniters
- Laser Mapping Machine Motion
- Up to 140' Effective Cutting Length



**CUTTING SYSTEMS, INC.**

Cleveland, Ohio 44105

P: 216.928.0500 • F: 216.928.0502

[www.cuttingsystems.com](http://www.cuttingsystems.com)